



APACHE A-9 AVIATOR

Night Vision Aviation Goggle System

USER MANUAL

© 2019 AGM Global Vision. All rights reserved worldwide.

This documentation is subject to change without notice.

No parts of this manual, in whole or in part, may be copied, photocopied, translated, or transmitted by any electronic medium or in machine-readable form without the prior written permission of AGM Global Vision.

If you have questions that are not covered in this manual, or need service, contact AGM Global Vision customer support for additional information prior to returning a product.

AGM Global Vision

173 West Main Street

PO Box 962

Springerville, AZ 85938

Tel. 928.333.4300

Fax 480.393.4882

support@agmglobalvision.com

www.agmglobalvision.com

EXPORT INFORMATION

Buyer acknowledges that all products supplied by AGM Global Vision are subject to U.S. export control laws, including, but not limited to, the Export Administration Regulations, the International Economic Emergency Powers Act, and various U.S. embargoes and sanctions. AGM Global Vision products may not be exported, re-exported, or transferred contrary to U.S. export control laws. In particular, AGM Global Vision products may not be exported, re-exported, or transferred to prohibited countries, individuals, organizations, or entities, including but not limited to those individuals and entities listed on the List of Specially Designated Nationals and Blocked Persons administered or maintained by the U.S. Office of Foreign Assets Control ("OFAC"), the various lists maintained by the Bureau of Industry and Security of the Department of Commerce, and the U.S. State Department and Buyer represents and warrants that neither Buyer nor any of its officers, directors, or employees are on such lists. Distribution or resale by Buyer to such countries, individuals, organizations, or entities is expressly prohibited. Buyer has and will maintain a positive process to ensure compliance with this Section.

LIST OF CONTENTS

TITLE	PAGE
Safety Summary	4
SECTION 1. GENERAL INFORMATION	5
1.1 System Description	5
1.2 Key Features	5
1.3 Standard Components	6
SECTION 2. OPERATING INSTRUCTIONS	7
2.1 Installation and mounting	7
2.2 Controls and Indicators	10
2.3 Operating Procedures	11
SECTION 3. MAINTENANCE INSTRUCTIONS	14
3.1 Cleaning Procedures	14
3.2 Troubleshooting	14
3.3 Preparation for Extended Storage	16
SECTION 4. WARRANTY INFORMATION	17
4.1 Warranty Information and Registration	17
SECTION 5. SPECIFICATIONS	19
5.1 Specifications	19

SAFETY SUMMARY

- Read and follow all instructions
- Read all warnings
- Only use the attachments/accessories specified by the manufacturer
- All service must be provided by the manufacturer

Certain potentially dangerous conditions may be possible when using, maintaining, transporting or storing the Apache A-9 Goggle. To ensure safe operation, maintenance, transportation and storage, users should be aware of all safe practices and take all precautions listed below and throughout this manual.

WARNING:

It is required to preflight the Apache A-9 Pilot/Aviator Night Vision Imaging System. Failure to conduct preflight inspection of the goggle and verifying proper operational performance can jeopardize pilot operations and risk mission and/or crew safety. Failure to preflight the goggle may also void the user's FAA Airworthiness Certification. Consult your flight operations director for guidance.

Operators are required to document Apache A-9 operational performance by logging preflight inspection results in the Operator Log Book prior to each flight.

WARNINGS:

There are no user-serviceable parts inside the Apache A-9 Goggle. Disassembling any of the components, circuitry or sub-components, could result in operational malfunction, damage to equipment, and/or flight safety issues. Servicing should only be attempted by qualified technicians who are familiar with and trained in the proper servicing of an Apache A-9 night vision device. Unauthorized attempts to service the Goggle will void the warranty and void any FAA Continued Flight Worthiness Certifications.

CAUTIONS:

To reduce the possibility of corrosion damage due to battery leakage, remove batteries from the Battery Pack before extended storage or projected long periods of non-use, as well as after a set of batteries has lost its charge.

The Apache A-9 has been designed, built, and tested to ensure optimal performance despite rugged handling or adverse conditions, and it comes complete with an integral water-resistant protective case. It is, however, a precision instrument, and should be handled and transported with care to ensure long life and trouble-free operation. Do not drop, throw, strike, or otherwise carelessly mishandle the Apache A-9.

1 GENERAL INFORMATION

1.1 SYSTEM DESCRIPTION

This manual provides instructions for the operator to use and maintain the Aviator's Night Vision Imaging System (ANVIS) Model Apache A-9 (see Figures 1-1). The Apache A-9 is a self-contained night vision device that enables improved night vision using ambient light from the night sky (moon, stars, sky glow, etc.). The Apache A-9 is a helmet-mounted passive binocular that provides the capability for pilots to fly in terrain flight modes at night. The system amplifies ambient light from sources such as the moon, stars and sky glow so the viewed scene becomes clearly visible to the operator.

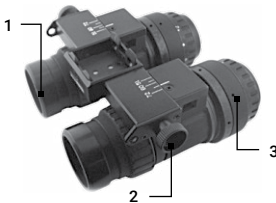

FIGURE 1-1. MAIN PARTS

TABLE 1-1. SYSTEM DESCRIPTION

ITEM	DESCRIPTION
1	Objective Lens Assembly
2	Eye-Span Knob
3	Eyepiece Assembly

1.2 KEY FEATURES

- Direct compatibility with Alpha 900 flight helmet
- Dual battery pack (primary and reserve source) with necessary counterweights
- Set of front and back tube covers
- Operating temperature: -32°C to + 52°C
- Shock resistance: 500G
- Low level battery warning
- Suitable for Rotorcraft
- Limited 3-year warranty

1.3 STANDARD COMPONENTS

The standard components are shown in Figure 1-2 and listed in Table 1-2.

The ITEM column indicates the number used to identify items in Figure 1-2.

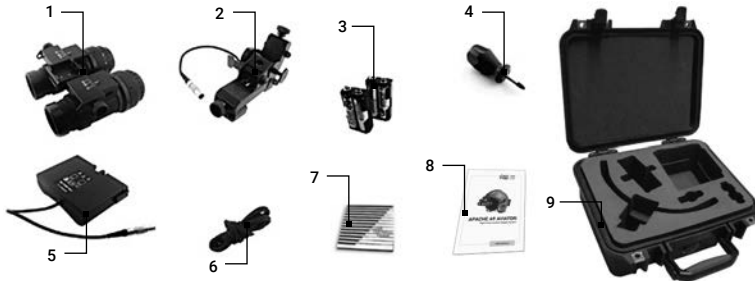

FIGURE 1-2. STANDARD COMPONENTS

TABLE 1-2. STANDARD COMPONENTS

ITEM	DESCRIPTION	QUANTITY
1	Apache A9 Binocular	1
2	Mount Assembly	1
3	AA Battery Cartridges	2
4	Screwdriver	1
5	Low-Profile Battery Pack	1
6	Neck Cord	1
7	Lens Tissue	1
8	User Manual	1
9	Carrying Case	1

2 OPERATING INSTRUCTIONS

2.1. INSTALLATION AND MOUNTING

CAUTION:

To protect the intensifier tube when the sight is not in use or when it is being operated in daylight, keep the protective lens cap securely fitted over the lens.

2.1.1 BATTERY AND POWER PACK INSTALLATION

WARNING:

Inspect the batteries for damage or defects before using them. If the batteries are damaged or show signs of leakage, do not use with the Apache A-9.

CAUTION

Be sure the power pack is switched off before installing the batteries.

NOTE:

The primary battery compartment is the right compartment from the aviator's perspective. The alternate compartment is the left compartment from the aviator's perspective.

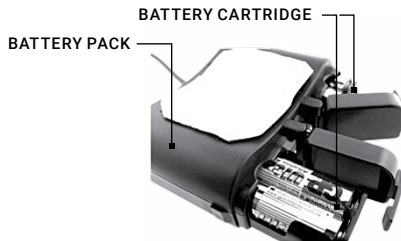

FIGURE 2-1. BATTERY INSTALLATION

The batteries mounted in a battery cartridge are inserted into the battery pack as follows (refer to Figure 2-1). The battery cartridge will accept two 1.5V AA batteries.

1. Push the battery pack doors up (open)
2. Remove the cartridges containing the two 1.5V AA batteries.
3. Check to make sure the interior of each battery compartment is clean.
4. The required polarity for the battery is illustrated on the inside of the cartridge module. Insert the replacement battery into each battery cartridge module (Figure 2-2)
5. Insert the battery cartridges into the battery pack and close the battery pack doors



FIGURE 2-2. BATTERY CARTRIDGES

NOTE

It is recommended to use fresh (unused) batteries in the alternate (left) compartment (from the aviator's perspective) before beginning a mission. Some batteries that have been used and still have many hours of life remaining can be used depending on unit procedures. Make sure to install these used or "time" batteries in the primary (right) compartment (from the aviator's perspective).

2.1.2 LOW BATTERY INDICATOR CHECK

At the base of the Apache A-9 mount is a red light-emitting diode (LED) that comes on or blinks at a steady rate when battery voltage is low (see Figure 2-3). To make sure this indicator works, perform the following check.

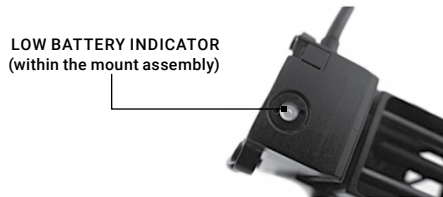

FIGURE 2-3. LOW BATTERY INDICATOR

CAUTION

The low-battery indicator must be checked without the binocular attached to the mount or in the flipped-up position.

1. With good batteries installed in both compartments of the power pack, take the battery cap to the alternate compartment. Pull the cartridge part way out, to make sure you break the electrical contact.
2. Turn the power switch to the alternate ON position (The compartment with the cap removed). The Low-battery indicator should come on or blink.
3. Return the switch to the OFF (middle) position and put the battery cap back on.
4. Take off the battery cap to the primary compartment. If using batteries, pull the cartridge part away out to make sure you break electrical contact.
5. Turn the power switch to the primary ON position (the compartment with the cap removed). The low-battery indicator should come on or blink.
6. If the low-battery indicator does not come on, replace the batteries with fresh ones and try again. Make sure the power cable is properly connected. If the indicator still does not function, return the Apache A-9 (with this power pack) and mount to Customer Support center.

2.1.3 ATTACHING THE BINOCULAR TO THE MOUNT

1. Make sure the power switch is turned OFF.



FIGURE 2-4. ATTACHING THE BINOCULAR TO THE MOUNT

2. Hold the binocular with both hands with the eyepieces facing you, and slide the spring-loaded ball bearings into the channels of the mount until they lock in place (see Figure 2-4).

3. Press the lock-release button (see Figure 2-5) and rotate the binocular to the up and lock position.



FIGURE 2-5 LOCK-RELEASE BUTTON

Press the lock-release button and ensure it locks properly

2.1.4 REMOVING THE BINOCULAR TO THE MOUNT

1. Make sure the power switch is turned OFF.
2. Hold the binocular with both hands with your thumbs on the PAS (Pivot Adjustment Shelf).
3. While pressing against the PAS, rotate binocular down then up.

CAUTION

DO NOT remove binocular by pulling or twisting. Damage to the binocular can occur and collimation may be adversely affected.

2.2 CONTROLS AND INDICATORS

2.2.1 OPERATOR CONTROLS AND INDICATORS

The Apache A-9 is designed to adjust for differences in head shape and corrects for most differences in eyesight. Figure 2-6 and Table 2-1 describes the controls and indicators.

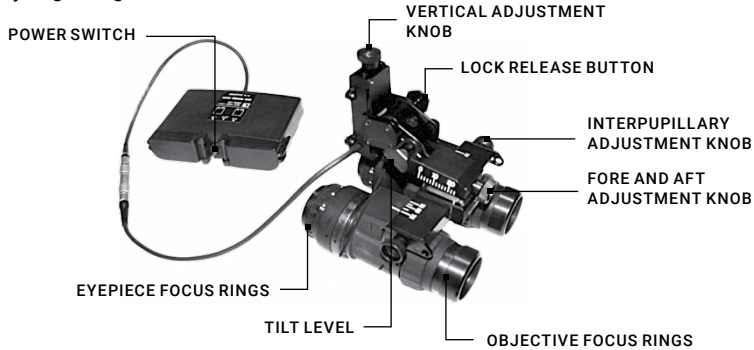

FIGURE 2-6 CONTROLS

TABLE 2-1. CONTROLS AND INDICATORS

CONTROLS & INDICATORS	FUNCTION
Power Switch	ON - binocular on, power drawn from battery compartment to switch points. OFF - binocular off. ON - binocular on, power drawn from battery compartment to switch points.
Objective Focus Rings	Focuses the objective lenses. Adjust for sharpest view of scene. Travel for the objective lens focusing is 1/3 turn.
Eyepiece Focus Rings	Focuses the eyepiece lenses to adjust for differences in eyesight. Adjust for sharpest image. Travel for eyepiece focus ring varies among eyepieces.
Eye Span Adjustment Knobs	Adjusts for different spacing between operator's eyes. The Apache A-9 6 has independent eye span adjustment, the left knob moves the left monocular and the right knob moves the right monocular. Turn the knob(s) to move the eyepieces together or apart for optimal spacing.
Fore and Aft Adjustment Knob	Adjusts for optimal viewing of the field of view. Turn the knob to obtain a full view of the image. Adjust the binocular as close as possible to your eyes to maximize the field of view and "look under" capability.
Vertical Adjustment Knob	Moves the binocular up or down in a vertical direction. Turn the knob to center the eyepieces in front of the eyes.
Tilt Level	Allows the binocular to be tilted up or down. Move the lever to obtain the optimum line-of-sight viewing.
Lock Release Button	Press the lock release button to rotate the binocular up or down.
Low-Battery Indicator	When illuminated, indicates a low battery condition with less than 30 minutes of battery life remaining.

2.3 OPERATING PROCEDURES

2.3.1 SETTING THE CONTROLS AND ADJUSTMENTS:

The Apache A-9 is designed to adjust for differences in head shape and correct for most differences in eyesight.

NOTE

Although the Apache A-9 is designed to be used without eyeglasses, if eyeglasses are needed to read the aircraft instruments and the eyeglass lenses will fit within the eye relief distance of the binocular's eyepiece, eyeglasses can and should be worn.

WARNING

If eyeglasses are worn, the eyeglasses upper rim can obscure the low-battery indicator.

NOTE

Before using the Apache A-9 for flight operations, be sure to check out the system's operation. Perform the checkout under darkened conditions. Use the following operating procedures for check out. If a failure occurs, refer to the troubleshooting procedures in Chapter 3, Section 2. If the problem persists, the system must be returned to Customer Support center.

1. Make sure the batteries are installed as described in paragraph 2-3A. Remove the lens caps.
2. Turn the power switch initially to the primary ON position. A green glow will appear in each eyepiece (after a slight delay). Begin in a mission with the power switch in this position as in the event of a failure; it is easier and more natural to flip the switch down than up.

NOTE

If a red light appears at the base of the Apache A-9 mount, the batteries in that compartment are low and need to be replaced. Switch to the other battery compartment and make sure those batteries are good.

3. Turn the vertical adjustment knob (see Figure 2-7) to center the eyepieces in from of your eyes. Minor readjustment may be needed after adjusting the tilt lever.

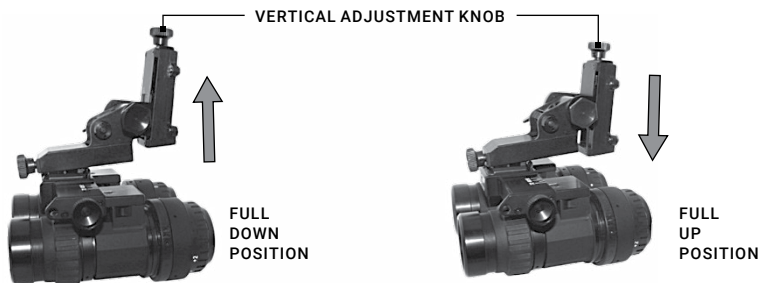

FIGURE 2-7. VERTICAL ADJUSTMENT KNOB

NOTE

If the Apache A-9 eyepieces are not properly aligned with the eyes, optimal resolution will not be achieved. Proper alignment of the eyepieces is achieved when the distance between the monocular matches the distance between your pupils and the line of sight is the same as the vertical angle of the binocular. When all the eyepiece adjustments (eye-span, vertical and tilt) are properly set, the edges of the images in both monoculars will be clear.

CAUTION

Do not attempt to adjust the tilt angle of the binoculars by pushing or pulling the monoculars up and down as this will damage the adjustment mechanism. Use only the tilt lever to make tilt angle adjustments.

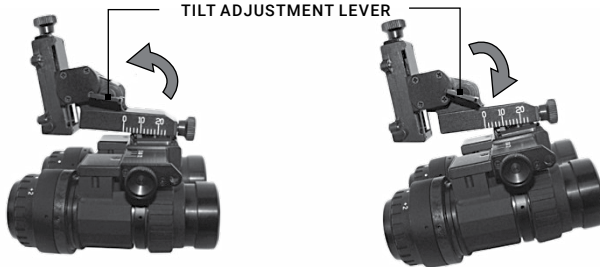

FIGURE 2-8. TILT LEVER

4. Move the tilt lever (see Figure 2-8) up or down to obtain the optimum line-of-sight view. If the upper or lower edges of the image areas are blurred, adjust both the vertical adjustment knob and the tilt lever until the blurred edge is removed and an optimal line of sight is achieved.



FIGURE 2-9. FORE-AND-AFT ADJUSTMENT KNOB

5. Turn the fore-and-aft adjustment knob (see Figure 2-9) to move the monoculars away from the eyes as far as possible without losing the field of view. This makes edge clarity easier to judge. You may use the fore-and-aft scale to preset this adjustment.

CAUTION

Do not attempt to adjust the eye-span distance by pulling the monoculars away from each other or pushing them together. Using force on the monoculars to make this adjustment will damage the adjusting mechanism inside the adjustment shelf. Use only the eye-span knob(s) to adjust the eye-span distance.

6. If your eye-span distance has been measured prior to mounting the binocular, turn the interpupillary knobs(s) (see Figure 2-10) to set this value on the scale. If not, move the binoculars closer together or further apart to adjust the eye-span distance for the proper spacing between your eyes. When properly adjusted, the edges of the images in both monoculars will be clear and the resultant binocular view will appear as a single circle or as two circles, overlapped and slightly displaced laterally.
7. Now, turn the fore-and-aft adjustment knob to move the monoculars closer to the eyes as desired for individual preference. Your eyelashes should not touch the lenses or the assembly. A 25mm distance between the eye and the eyepiece provides for optimal viewing.

3 MAINTENANCE INSTRUCTIONS

3.1 CLEANING PROCEDURES

Wipe the housing with a damp cloth as needed.

CAUTION:

Do not use abrasives or solvents to clean the housing, lens, or display window of the device. Do not use ammonia-based cleaning products to clean the lens. Doing so may damage the anti-reflective coating of the lens.

The Apache A-9 lens is designed for the harsh outdoor environment and has a coating for durability and anti-reflection, but it may require occasional cleaning. Avoid scratching the lens and/ or leaving fingerprints on the optics. Improper cleaning can damage the optics. Clean the lens according to the instructions below.

Do not use abrasive materials, such as paper or scrub brushes, as this can scratch or otherwise damage the lens. Only wipe the lens clean when there is visible contamination on the surface.

Preferred Method for Cleaning the Lens

Materials:

- Optical-grade cloth
- Pure water (deionized or other)
- Isopropyl alcohol (IPA)

Saturate a piece of the lens tissue with water and drape it over the lens. Let the surface tension of the water pull the tissue onto the lens surface. Drag the tissue across the lens surface. Repeat several times with different pieces of tissue.

Repeat the same step using isopropyl alcohol instead of water. Drag the final piece of tissue over the lens several times to prevent pooling, which may leave a residue behind.

3.2 TROUBLESHOOTING

Table 3-1 lists the most common malfunctions that may occur with your equipment. Perform the tests, inspections, and corrective actions in the order they appear in the table.

This table does not list all the malfunctions that may occur with your device, or all of the tests, inspections, and corrective actions that may be necessary to fix them. If the equipment malfunction is not corrected by the suggested actions, or a problem occurs that is not listed in this table, please contact AGM Global Vision's Customer Support center or your retailer.

TABLE 3-1. TROUBLESHOOTING

PROBLEM	PROBABLE CAUSE	CORRECTIVE ACTION
Binocular will not come on.	Batteries are defective.	Replace batteries.
	Batteries are missing or improperly installed.	Insert batteries or install batteries correctly.
	Electrical contacts are dirty or corroded.	Use a dry cloth or pencil eraser to clean all electrical contacts.
	Power cable connectors are not properly engaged.	Reconnect.
	Broken power cord, mount or power pack.	If power cord is damaged, return Apache A-9 and/or mount to Customer Support center.
Intermittent operation.	Defective mount or binocular.	Return Apache A-9 and mount to Customer Support center.
Poor image quality.	Objective lenses or eyepiece lenses not focused correctly or lenses are fogged or dirty.	Adjust the focus of the lenses or clean them. If the image is still not clear, or the lenses are fogged internally, return to Customer Support center.
Objective cannot be focused.	Focus mechanism loose or broken.	Return Apache A-9 to Customer Support center.
Eyepiece cannot be focused.	Eyepiece loose or focus mechanism broken.	Return Apache A-9 to Customer Support center.
Eye-span adjustment cannot be made.	Defective eye-span mechanism.	Return Apache A-9 to Customer Support center.
Binocular will not lock in mount.	Mounting hardware is dirty or broken.	Clean the mounting hardware. If problem persists the mechanism is damaged. Return the Apache A-9 and mount to Customer Support center.
Visor will not operate in mount.	Visor and mount improperly installed.	Return helmet mount to Customer Support center.
	Visor link defective.	Return helmet mount to Customer Support center.
Low battery indicator will not illuminate during check.	Batteries defective or missing.	Install new batteries.
	Batteries improperly installed.	Install correctly.
	AA cartridge not pulled part way out.	Pull partly out to break electrical contact.
	Poor power cable connection.	Check connector.
	Defective power pack.	Return Apache A-9 to Customer Support center.
	Defective mount.	Return Apache A-9 to Customer Support center.

PROBLEM	PROBABLE CAUSE	CORRECTIVE ACTION
Operator experiences eyestrain, headache, or nausea while using goggles.	Incorrect sight picture or focus.	Correct sight picture or focus.
	Collimation off, poor image, adjustment shelf defective or defective monocular housing.	Turn in binocular to maintenance personnel for collimation check, visual image dark, and adjustment shelf as well as monocular housing check.

3.3 PREPARATION FOR EXTENDED STORAGE

Before the Apache A-9 Goggle is put away for an extended period of non-use:

- Make sure all optics lenses are clean and dry.
- Place protective caps on eye-pieces and objective lenses
- If batteries are installed, remove the batteries from the battery pack. Batteries may be stored in the case.
- Store all Goggle components in its protective case.
- While not in use, do not stack heavy items on top of the protective case.

4 WARRANTY INFORMATION

4.1 WARRANTY INFORMATION AND REGISTRATION

4.1.1 WARRANTY INFORMATION

This product is guaranteed to be free from manufacturing defects in material and workmanship under normal use for a period of three (3) years from the date of purchase. In the event that a defect covered by the warranty below occurs during the applicable period stated above, AGM Global Vision, at its discretion, will either repair or replace the product; such action on the part of AGM Global Vision shall be the full extent of AGM Global Vision's liability, and the Customer's sole and exclusive repairation. This warranty does not cover a product if it has been (a) used in ways other than its normal and customary manner; (b) subjected to misuse; (c) subjected to alterations, modifications or repairs by the Customer or by any party other than AGM Global Vision without prior written consent of AGM Global Vision; (d) is the result of a special order or categorized as "close-out" merchandise or merchandise sold "as-is" by either AGM Global Vision or the AGM Global Vision dealer; or (e) merchandise that has been discontinued by the manufacturer and either parts or replacement units are not available due to reasons beyond the control of AGM Global Vision. AGM Global Vision shall not be responsible for any defects or damage that in AGM Global Vision's view are a result from the mishandling, abuse, misuse, improper storage or improper operation of the device, including use in conjunction with equipment that is electrically or mechanically incompatible with, or of inferior quality to, the product, as well as failure to maintain the environmental conditions specified by the manufacturer. This warranty is extended only to the original purchaser. Any breach of this warranty shall be enforced unless the customer notifies AGM Global Vision at the address noted below within the applicable warranty period.

The customer understands and agrees that except for the foregoing warranty, no other warranties written or oral, statutory, expressed or implied, including any implied warranty of merchantability or fitness for a particular purpose, shall apply to the product. All such implied warranties are hereby and expressly disclaimed.

4.1.2 LIMITATION OF LIABILITY

AGM Global Vision will not be liable for any claims, actions, suits, proceedings, costs, expenses, damages, or liabilities arising out of the use of this product. Operation and use of the product are the sole responsibility of the Customer. AGM Global Vision's sole undertaking is limited to providing the products and services outlined herein in accordance with the terms and conditions of this Agreement. The provision of products sold and services performed by AGM Global Vision to the Customer shall not be interpreted, construed, or regarded, either expressly or implied, as being for the benefit of or creating any obligation toward any third party of legal entity outside AGM Global Vision and the Customer; AGM Global Vision's obligations under this Agreement extend solely to the Customer. AGM Global Vision's liability hereunder for damages, regardless of the form or action, shall not exceed the fees or other charges paid to AGM Global Vision by the customer or customer's dealer. AGM Global Vision shall not, in any event, be liable for special, indirect, incidental, or consequential damages, including, but not limited to, lost income, lost revenue, or lost profit, whether such damages were foreseeable or not at the time of purchase,

and whether or not such damages arise out of a breach of warranty, a breach of agreement, negligence, strict liability, or any other theory of liability.

4.1.3 PRODUCT REGISTRATION

In order to validate the warranty on your product, the customer must complete and submit AGM Global Vision PRODUCT REGISTRATION FORM on our website (www.agmglobalvision.com/customer-support).

4.1.4 OBTAINING WARRANTY SERVICE

To obtain warranty service on your unit, the End-user (Customer) must notify the AGM Global Vision service department via e-mail. Send any requests to support@agmglobalvision.com to receive a Return Merchandise Authorization number (RMA). When returning any device, please take the product to your retailer, or send the product, postage paid and with a copy of your sales receipt, to AGM Global Vision's service center at the address listed above. All merchandise must be fully insured with the correct postage; AGM Global Vision will not be responsible for improper postage or merchandise that becomes lost or damaged during shipment. When sending product back, please clearly write the RMA# on the outside of the shipping box. Please include a letter that indicates your RMA#, the Customer's Name, a Return Address, reason for the return, contact information (valid telephone numbers and/or an e-mail address), and proof of purchase that will help us to establish the valid start date of the warranty. Product merchandise returns that do not have an RMA# listed may be refused, or a significant delay in processing may occur. Estimated Warranty service time is 10-20 business days. The End-user/Customer is responsible for postage to AGM Global Vision for warranty service. AGM Global Vision will cover return postage/shipping after warranty repair to the End-user/Customer only if the product is covered by the aforementioned warranty. AGM Global Vision will return the product after warranty service by domestic UPS Ground service and/or domestic mail. Should any other requested, required, or international shipping methods be necessary, the postage/shipping fee will be the responsibility of the End-user/Customer.

For service, repair or replacement, please contact:

AGM Global Vision

173 West Main Street

PO Box 962

Springerville, AZ 85938

Tel. 928.333.4300

Fax 480.393.4882

support@agmglobalvision.com

www.agmglobalvision.com

5 SPECIFICATIONS

5.1 SPECIFICATIONS

TABLE 5-1. APACHE A-9 SPECIFICATIONS

ITEM	DATA
Field of View	40°
Magnification	1.0x
System Resolution	1.3 cy/mR minimum
Diopter Adjustment	-6 to +2
IPD	51–72 mm
Vertical Adjustment	25 mm
Fore/Aft Adjustment	27 mm
Collimation: - Convergence - Divergence	1.0° 0.33°
Tilt Adjustment	10°
Focus Range	25 cm to infinity
Battery Type	AA 1.5VDC
Battery Life	80 hours battery pack load
Operating Temperature Range	-32°C to 52°C
Storage Temperature Range	-35°C to +71°C
Illumination Required	Overcast Starlight to Moonlight
Environmental Rating	MIL-STD-810H
Weight: - Binocular - Mount	500 g 150 g

NOTE:

All data subject to change without notice.



AGM Global Vision

MAIN OFFICE

173 West Main Street

PO Box 962

Springerville, AZ 85938

USA

Tel. +1.928.333.4300

Fax +1.480.393.4882

info@agmglobalvision.com

www.agmglobalvision.com

EUROPEAN OFFICE

Andrey Lyapchev #7

Sofia, P.C. 1756

Bulgaria

Tel. +44.292.255.0509

info@agmglobalvision.eu

www.agmglobalvision.eu

AGMglobalvision.com